

\_\_\_\_\_

\_\_\_\_\_

\_\_\_\_\_

## 一级代理商：

深圳市弗瑞鑫电子有限公司

地址：深圳市宝安区西乡大道302号金源商务大厦B座三楼

frxelec

1. F



2. D

3. A

4. F      D

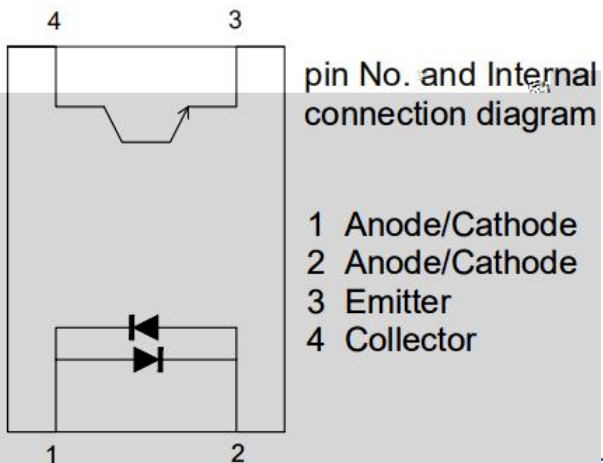

**5. A M R =25**

<b>P</b>			<b>R</b>	

1.
  - (1)
  - (2)
  - (3)
- 2.

---

6. E -O C ( =25 )  
P M .\* M C  
I  
O

PS\$

7. R

C

R

C R R

M

M

C

ORPC-814

A

50

8. O I

P N

**ORPC-814 - - - -**

N

9. N R

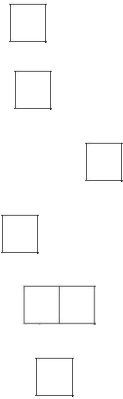
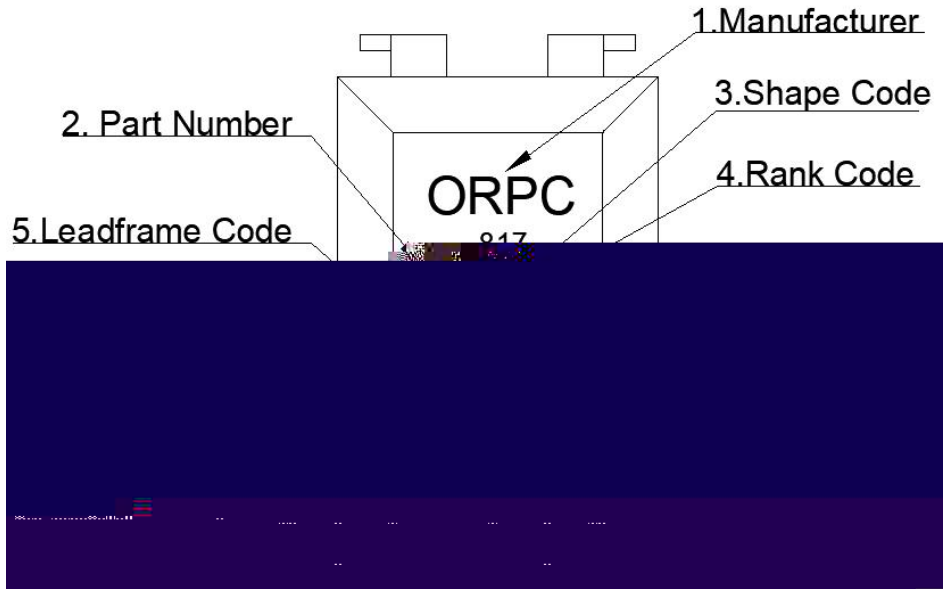

# 10. P D (

## 1. ORPC-814

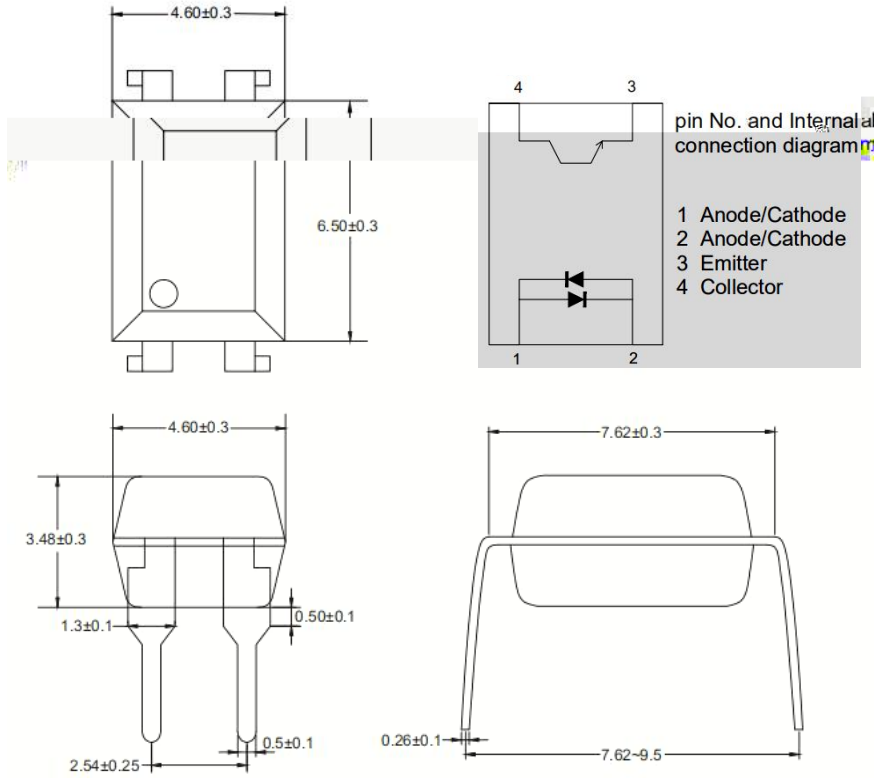

## 2. ORPC-814M

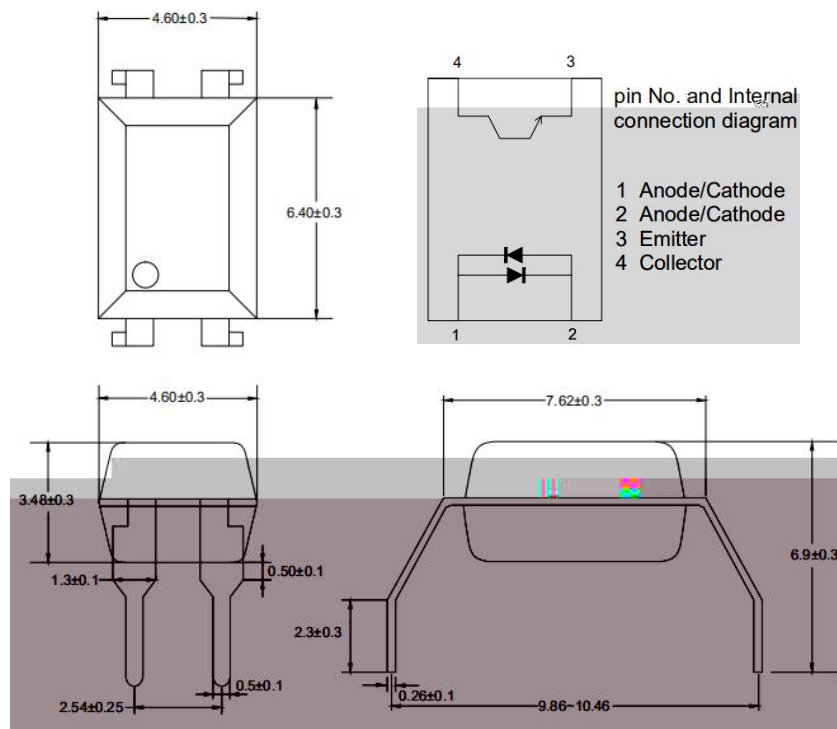

### 3. ORPC-814

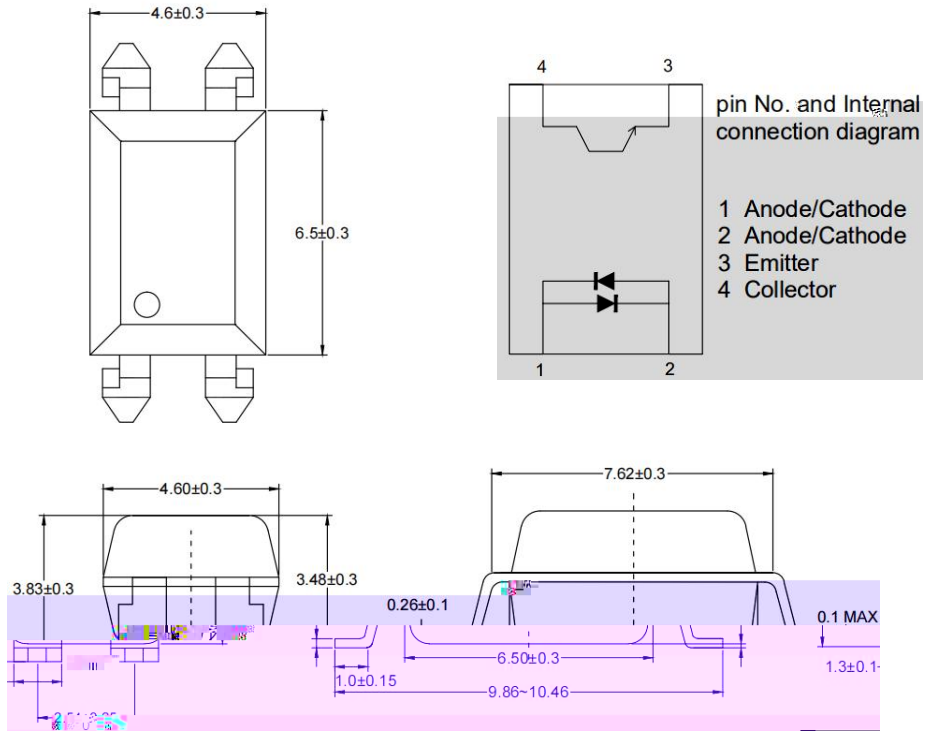

11. D

(1)ORPC-814 - P

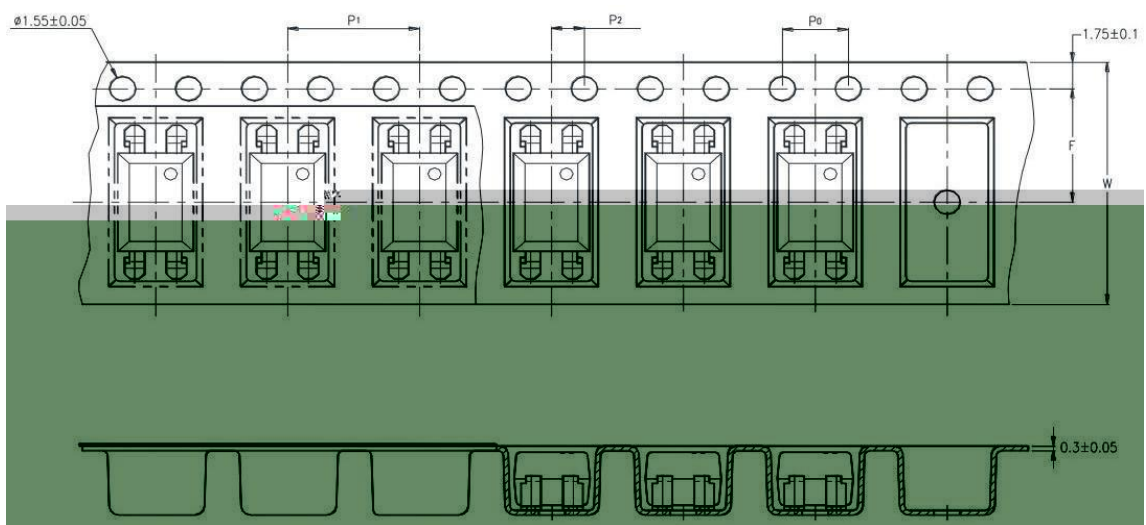



(2)ORPC-814 - P1

12. R F P P (M P ) (



14. R

NO.	ITEM	Q (P )	C	P	D
	R H				
	▪				
	H L				
	▪				
	L L				
	C				



(2). (JEDEC22A111 )



(3).H

Temperature	380+0/-5°C
Time	3 sec max

16. C C

Fig.1 Forward current vs Ambient temperature

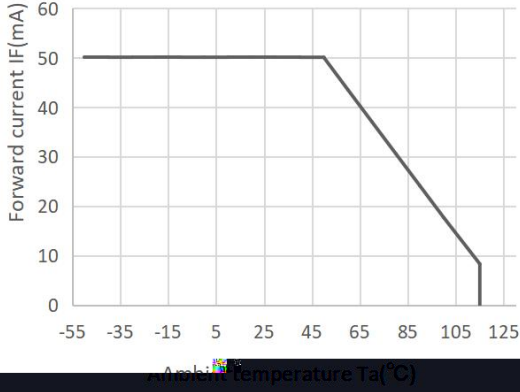

Fig.2 Collector Power Dissipation vs. Ambient temperature

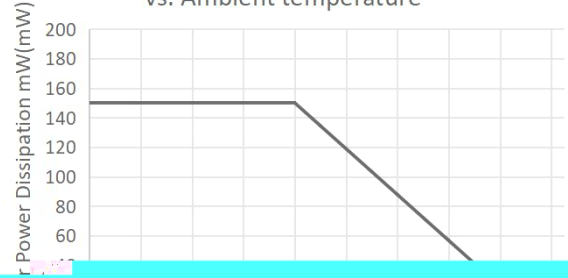

Fig.3 Collector-emitter Saturation Voltage vs. Forward Current

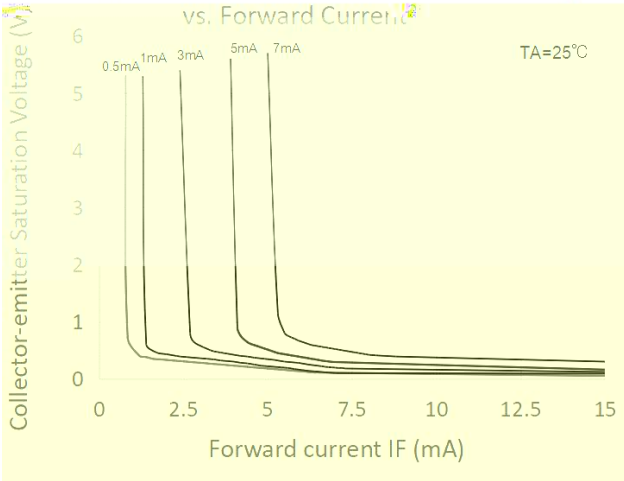

Fig.4 Forward Current vs. Forward Voltage

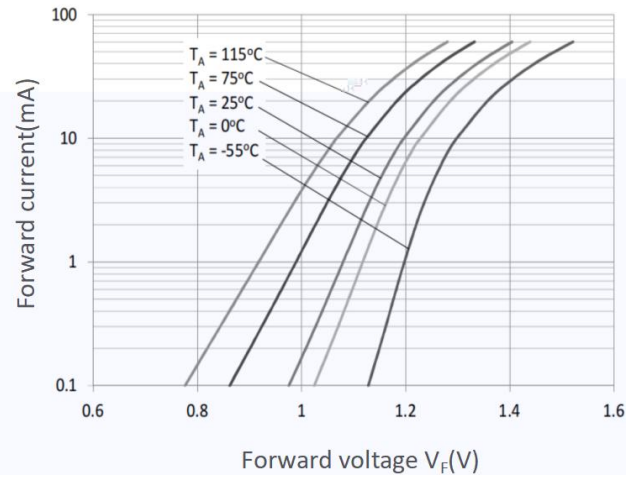

Fig.5 Forward Current vs. Current Transfer Ratio

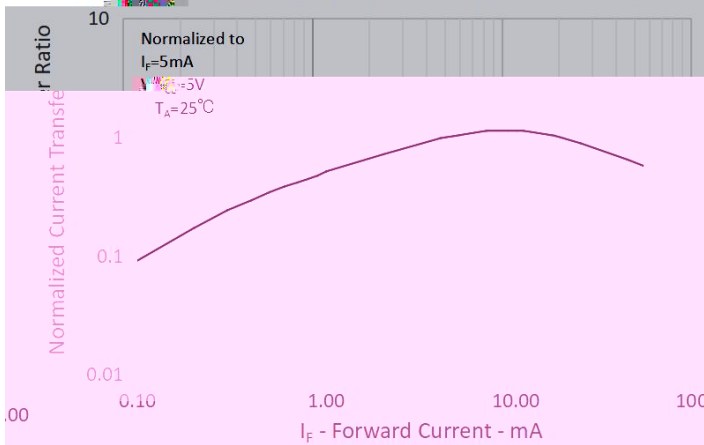

Fig.6 Collector Current vs. Collector-emitter Voltage

